

166/183GHz Diplexer Final Review

Pre-development of Critical
Technology for MetOp-SG
MWS Instrument

yvonne.munro@astrium.eads.net

mike.winsor@astrium.eads.net

20 March 2013

CEOI

Study Objectives

- Design of a waveguide diplexer for separating the 166 GHz and 183 GHz channels for the MetOp-SG MWS instrument to achieve an insertion loss of $< 0.5\text{dB}$;
- Manufacture 4 x 166/183 GHz waveguide diplexers and verification that the required mechanical tolerances have been achieved;
- RF testing of the 4 waveguide diplexers to establish the insertion loss performance over the required 165 and 183 GHz MWS channels;

Study organisation

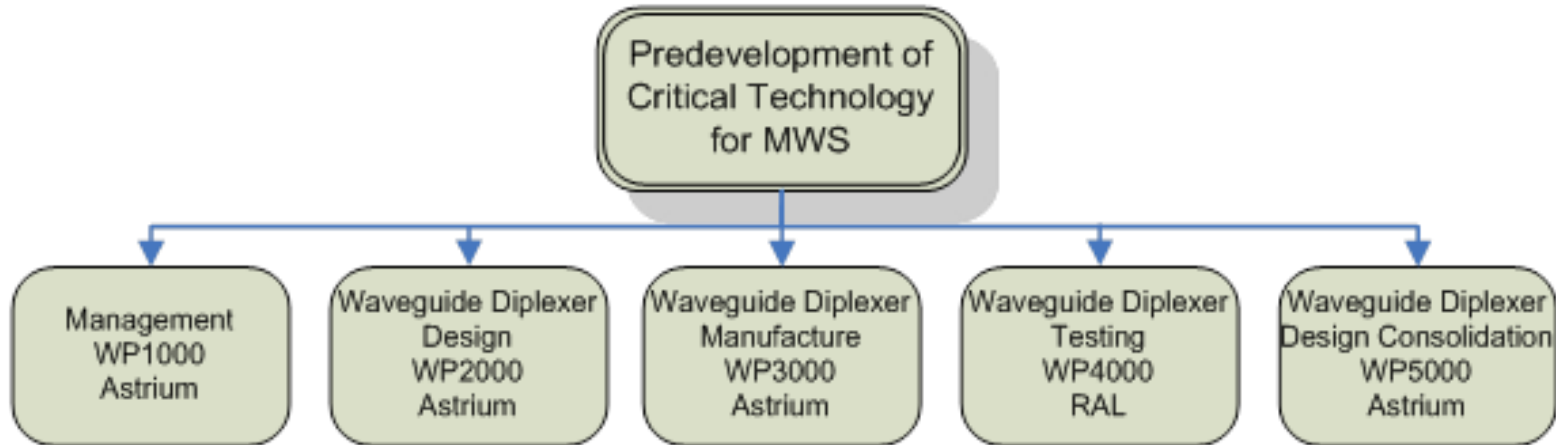

- Astrium Ltd is responsible for the management of the study activities, diplexer design and analysis,
- RAL for the provision of test equipment and facilities and for the RF testing.
- Manufacture of the waveguide diplexers was undertaken by Thomas Keating

Technical challenges

■ Design:

- In-band insertion loss less than -0.5dB
- Inter-band rejection better than -20dB
- Input and output port return loss better than -15dB

■ Manufacture:

- Diplexer cross-section requires electroforming
- Achieving dimensions and surface roughness of 5 μ m

■ Test

- Potential for measurement and calibration errors at high frequencies

Diplexer characteristics

- Pass bands 164 to 167GHz and 175 to 191GHz
- In-band insertion loss goal to be less than -0.5dB
- Inter-band rejection goal to be better than -20dB
- Input and output port return loss goal to be better than -15dB
- Use standard waveguide interfaces

Analysis results

- A trade off resulted in the selection of a design using thick irises which is relatively tolerant to rounding of internal corners and manufacturing tolerances compared to designs using thin irises.
- A HFSS analysis model was developed that included internal corner rounding of 80µm to simulate spark erosion and conductivity of 20e6 S/m to model gold plating conductivity at 170GHz.
- In-band insertion loss less than -0.28dB (goal -0.5dB)
- Inter-band rejection better than -24dB (goal -20dB)
- Input and output port return loss better than -18dB (goal -15dB)
- Standard waveguide interfaces

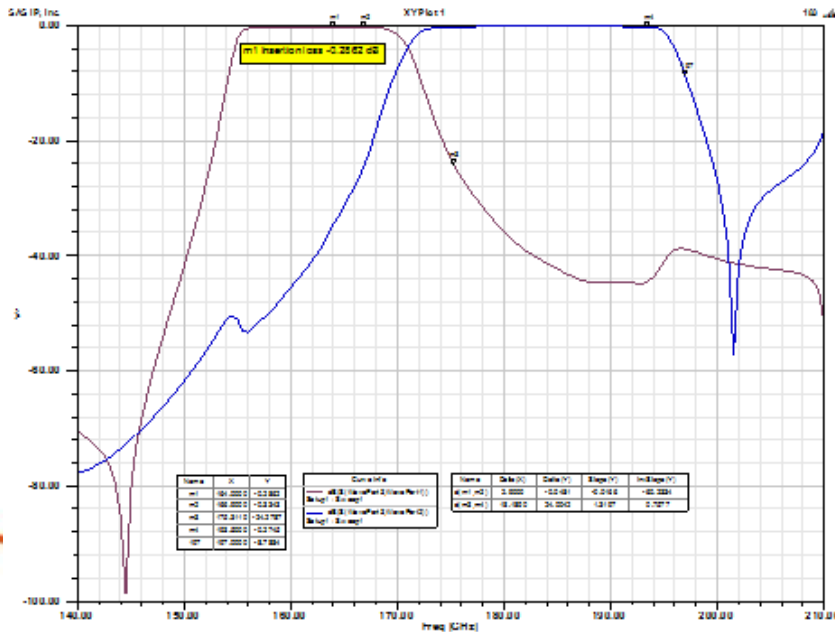

Mandrel cross section

Low band port

High band port

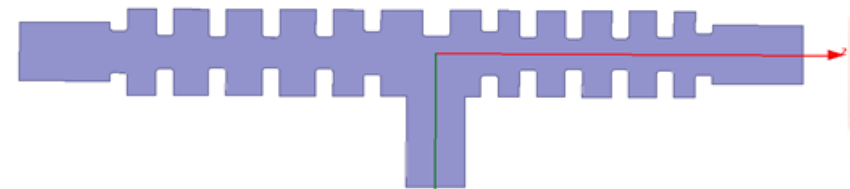

Common input port

Manufacturing process -Thomas Keating Ltd

- Machine aluminium blank to form a mandrel of the internal shape of diplexer
- Gold plate 1.8µm on finished mandrel
- Electroform main copper body over plated mandrel
- Machine outer body
- Remove mandrel by acid etching
- Attach flanges
- Lap flange interfaces
- Gold plate outer surfaces

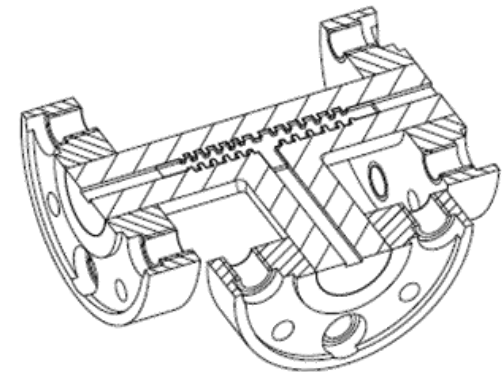

Wire erosion of mandrel blank



CNC milling of perspex mask



Electroforming of diplexers



Physical realisation

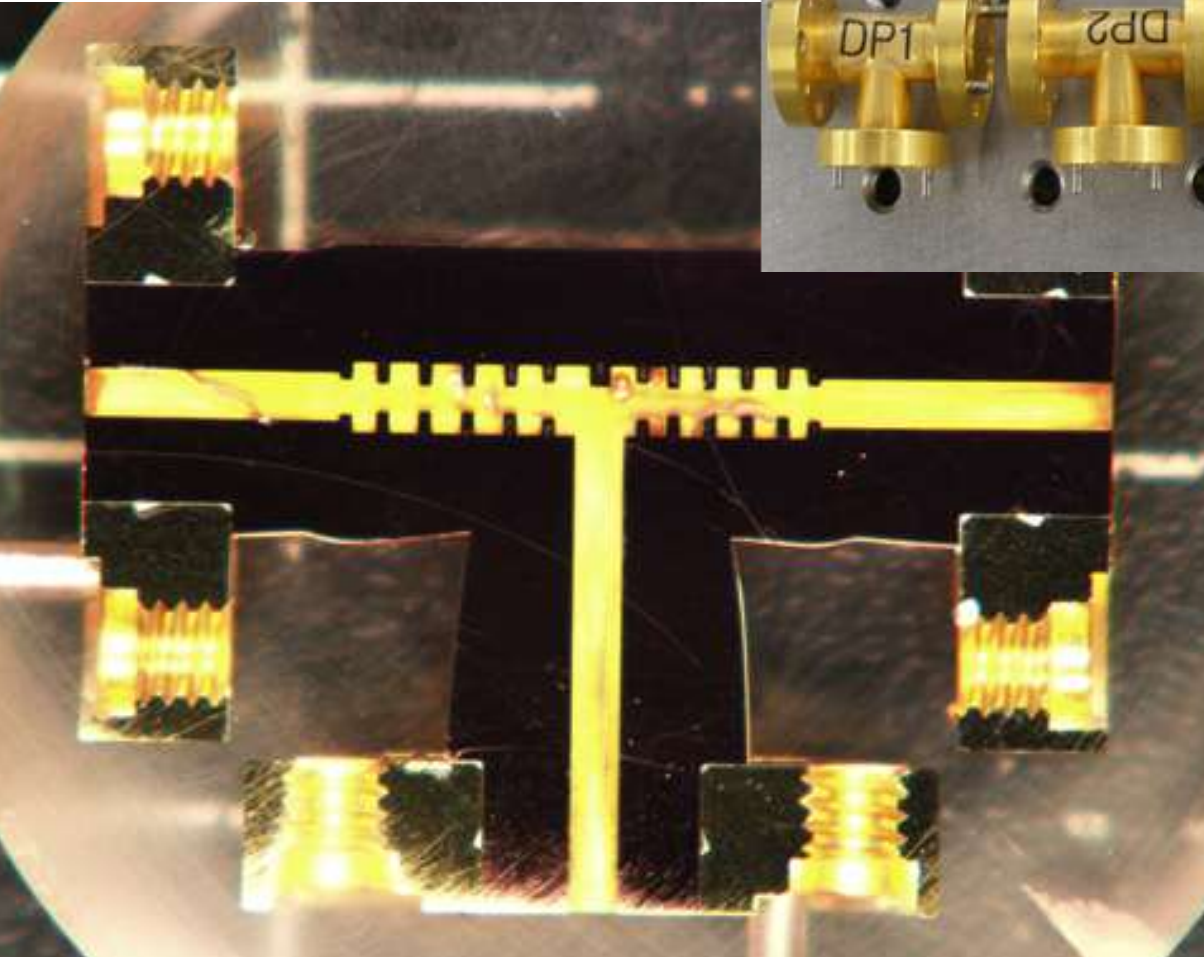

Volume of diplexer;
23mm x 19mm x 28mm

Mass of diplexer 37g.

This document and its content is the property of Astrium [Ltd/SAS/GmbH] and is strictly confidential. It shall not be communicated to any third party without the written consent of Astrium [Ltd/SAS/GmbH].

Measurement configuration at STFC RAL

- Four devices were tested using RAL's AB Millimetre Vector Network Analyser (MVNA).

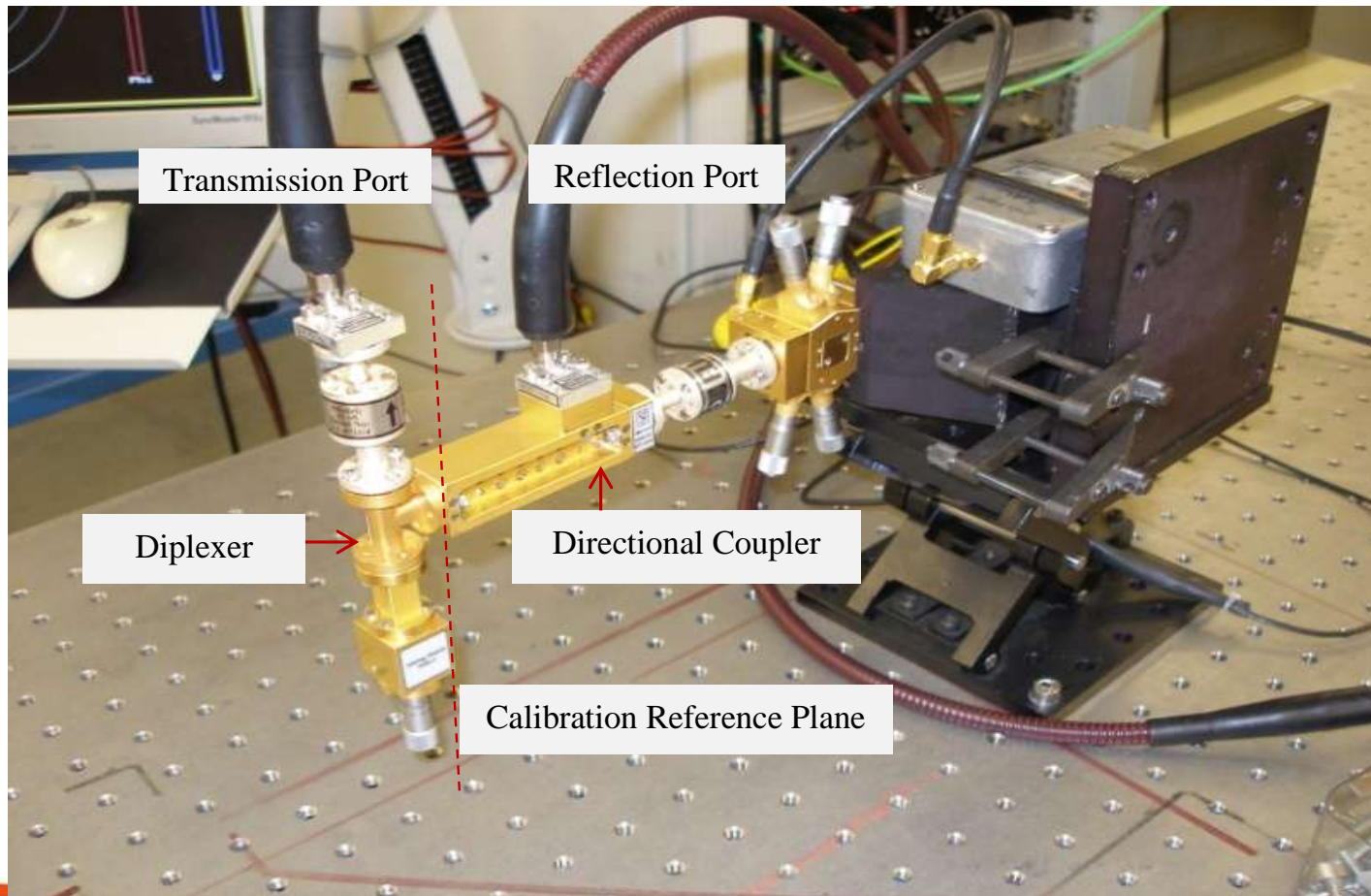

Measured results

- Frequency response of diplexers 1 to 3 showed close agreement with the frequency response of the model, whereas number 4 showed a slight notch in its upper band response.
- All 4 diplexers showed higher insertion loss than expected.
- Low band insertion loss of diplexers ranged from -0.72dB to 0.84dB (goal -0.5dB)
- High band insertion loss of diplexers ranged from -0.65dB to 0.82dB (goal -0.5dB)
- Inter-band rejection of all diplexers was better than -23dB (goal -20dB)
- Input and output port return loss on all ports was better than -18dB (goal -15dB)

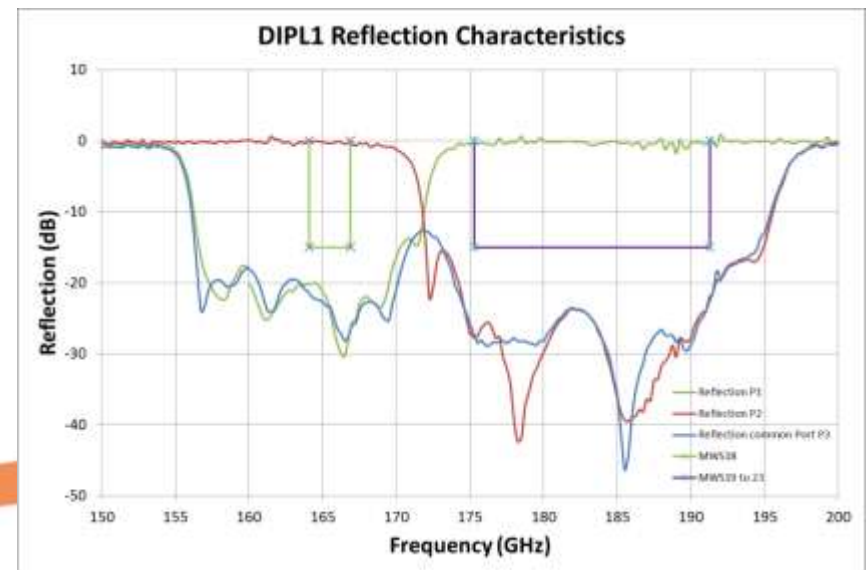
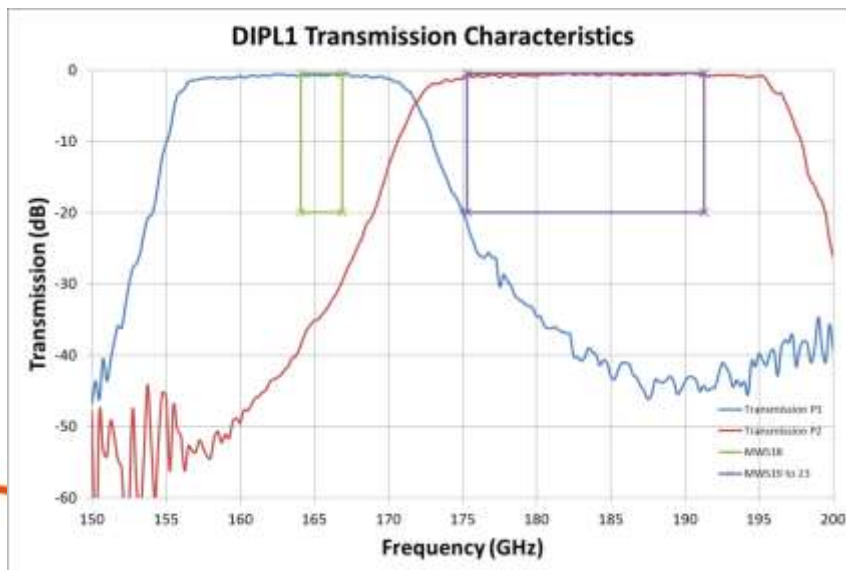

Post-production analysis (a)

Diplexer 4 was cross sectioned and found to have an average gold plate thickness of 1.8 μm , a surface roughness of 2.75 μm and internal corner rounding ranging from 90 μm to 110 μm .



HFSS analysis showed that surface roughness has a major influence on insertion loss. Internal rounding has a major effect on the frequency response similar to that seen of number 4. It was observed that the original HFSS model did not include surface roughness.

HFSS model was modified to include surface roughness of 2.75 μm , plating thickness of 1.8 μm , and conductivity of 29.9e6 S/m and internal radii of 80 μm and predicted low band insertion loss of -0.74dB.

The HFSS model is valid as analysed results are very similar to measured results using measured mechanical data.

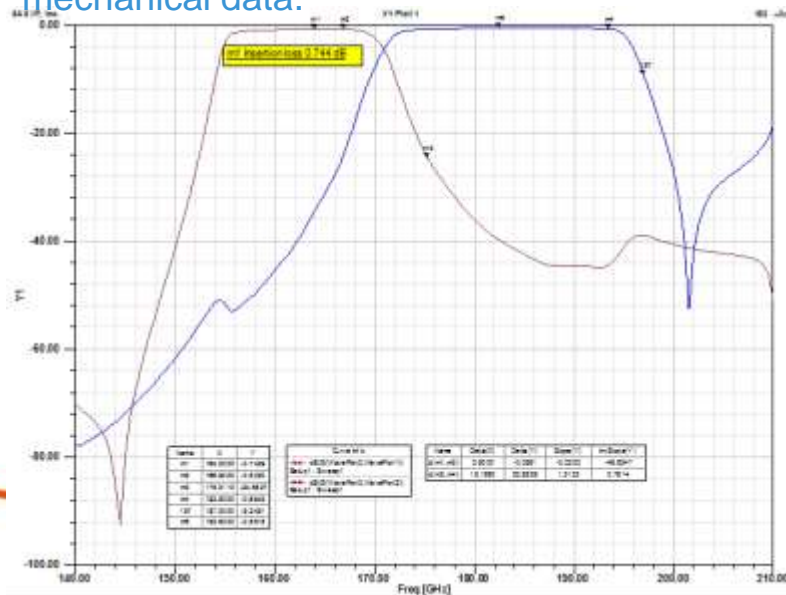

Post-production analysis (b)

HFSS model analysis was run which included;

- Surface roughness of $1\mu\text{m}$
 - Average plating thickness of $2.0\mu\text{m}$
 - Plated silver conductivity of $50\text{e}6\text{ S/m}$
 - Internal corner rounding of $80\mu\text{m}$
-
- In-band insertion loss reduced to -0.58dB
 - Inter-band rejection was greater than -23dB
 - Return losses were better than -20dB

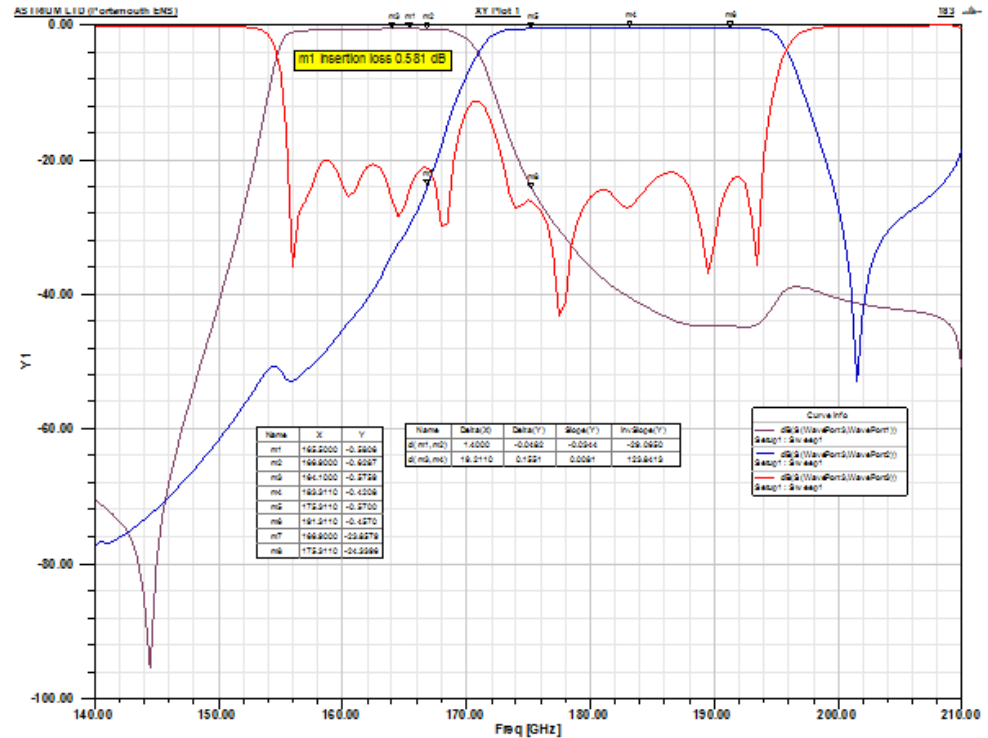

Next steps

- Produce a further 4 duplexers with improved surface finish and conductivity:
 - Polish the aluminium mandrel to a surface finish of $\sim 1\mu\text{m}$
 - Silver plate mandrel to a minimum of $2\mu\text{m}$ (~ 10 skin depths at 170GHz)
- Measure insertion loss of duplexers, inter-band rejection and input and output port return
- Compare with requirements and previous duplexer results
- Validate design