



ECIT

The Institute of Electronics,  
Communications and  
Information Technology



Queen's University  
Belfast

# Finite Frequency Selective Surface Modelling

CEOI 5<sup>th</sup> Open Call

Final Presentation 20<sup>th</sup> March 2013

Location: BMA House, Tavistock Square, London

R. Dickie, R. Cahill, V. F. Fusco

*High Frequency Electronics Circuits*



- The purpose of the project is to further develop the UK's expertise in electromagnetic modelling of finite FSS
- FSS are critical components in radiometer instruments used to direct the energy to receivers
  - QUB to provide accurate numerical prediction models for beam propagation and reflection
- Strengthens the UK's core instruments design capability by developing high performance computer models for incorporation into instrument design studies

- The 23.8 GHz channel has been selected to develop the finite FSS model as this receives the largest illumination in the QO system

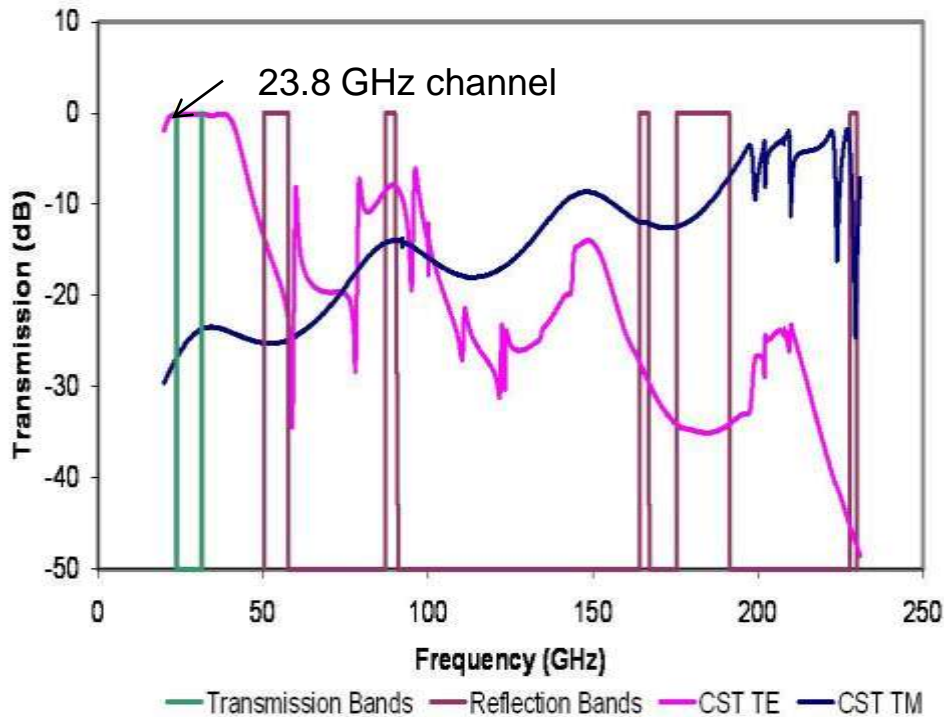

Parameter	Requirement
Transmission Bands	23.66 – 23.94 GHz 31.4 – 31.49 GHz
Transmission Insertion Loss	Target: 0.3 dB
Reflection Bands	50.21 – 57.67 GHz 87 - 91 GHz 164 - 167 GHz 175.3 – 191.3 GHz 228 – 230 GHz
Reflection Insertion Loss	0.3 dB
Incident Angle	45°
Physical diameter	250 mm

- This work builds on the ESTEC contract No. 22938/09/NL/JA to develop a FSS covering 23 – 230GHz.



- Floquet theorem, unit cell method is currently used to provide  $S_{21}$  and  $S_{11}$  scattering from the FSS, but does not provide radiation patterns
- For finite beam illumination and radiation patterns, two approaches were investigated
  - Complete array modelling
  - Finite FSS setup using a linear array

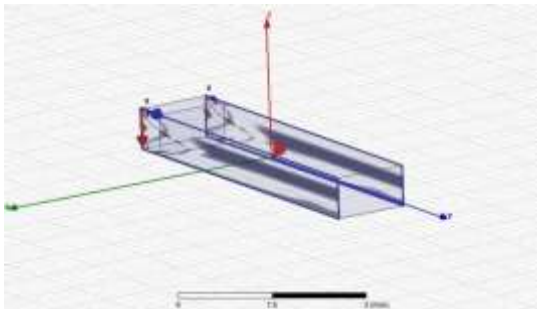

**Unit Cell Method**

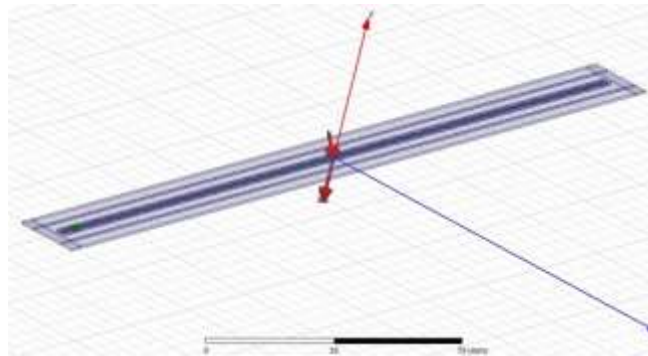

**Linear Array**

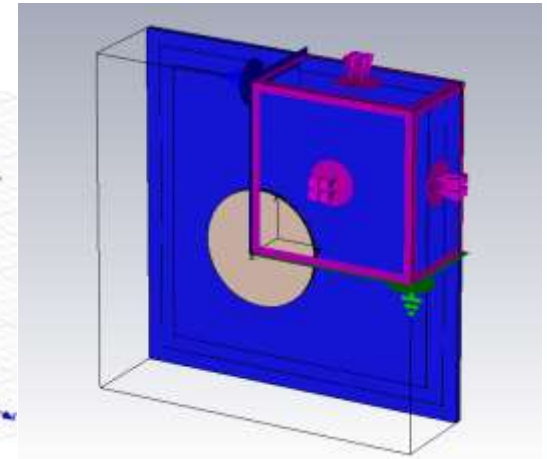

**Complete Array**

- Model requires a large volume to setup the Gaussian beam, CST TD Solver
- Modelling a significant challenge due to the 12.5 mm wavelength and small feature size of 0.03 mm, 1:420 ratio
- normal incident illumination 55 million mesh cells 79 hrs simulation time
- 45° incidence model requires 155 million mesh cells and is outside the two node GPU computing hardware capability

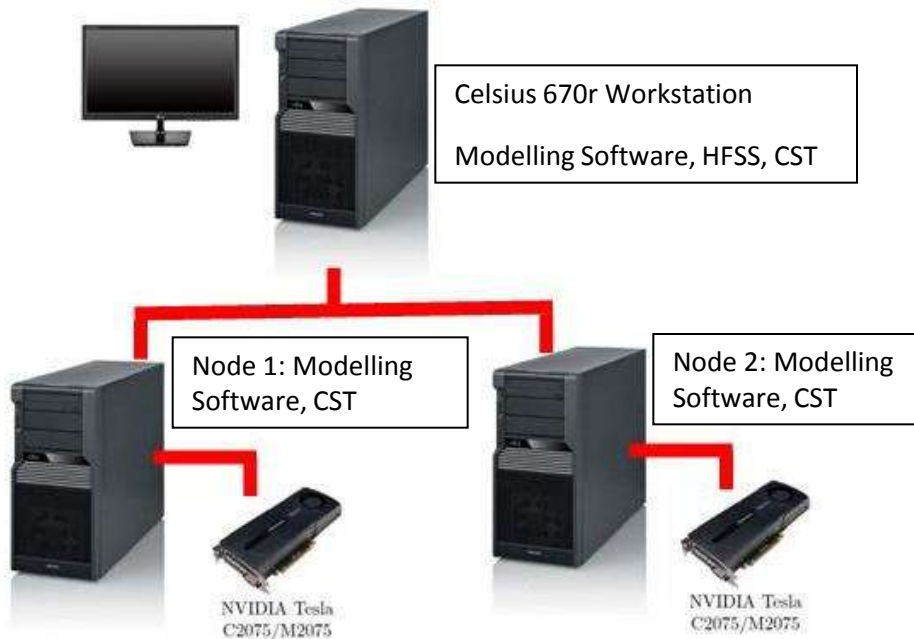

Hardware Setup

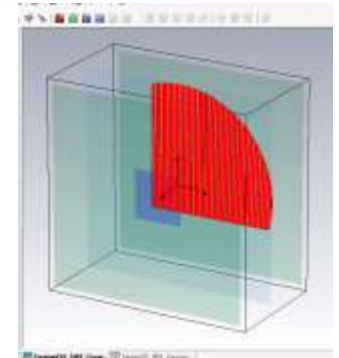
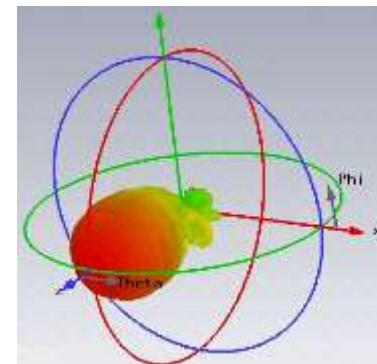
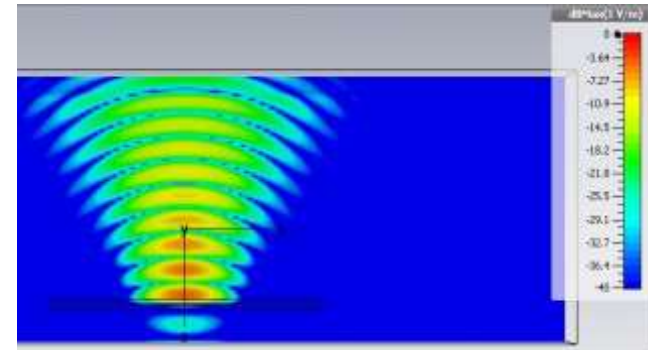

Finite FSS Modelling



- Modelling carried out in HFSS's frequency domain solver
- Model shows good convergence with pass number
- High growth in tetrahedral mesh cells with pass number, to 3.4 million
  - 80 GB machine memory required

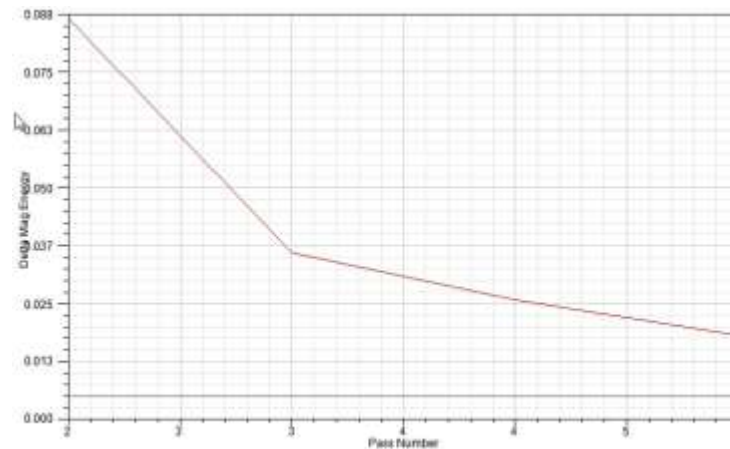

**Model convergence**

- S21 and S11 scattering calculations made on unit cell and linear array
- Good agreement with measured data and predictions, results shown for 23.8 GHz adaptively solved model

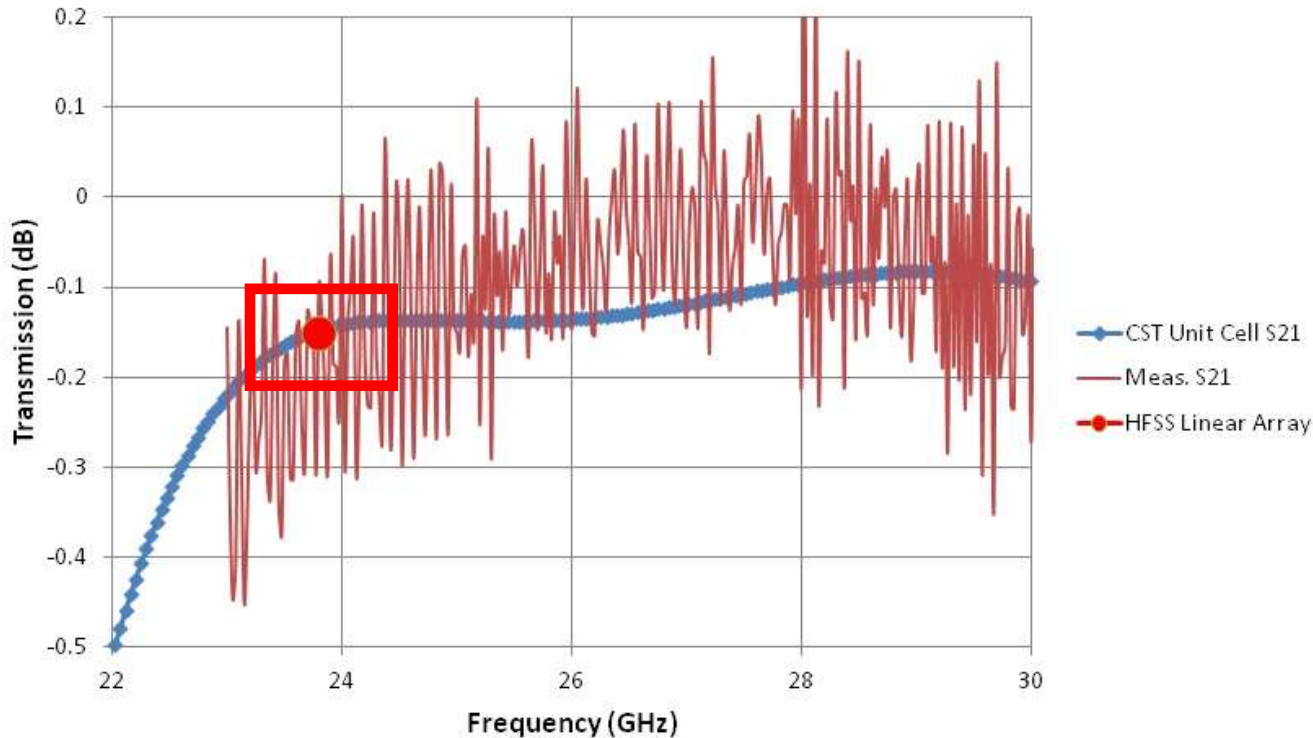

23 – 30 GHz transmission measurements carried out at RAL Space, STFC



# ECIT | Finite FSS Modelling Results (1-2)

- 48 mm radius Gaussian beam incident at  $45^\circ$  TE on the array
- Propagation main lobe transmitted through the FSS at  $45^\circ$
- The power reflected back in the direction of incidence is below -30 dB, shows low main beam side lobes at -20 dB

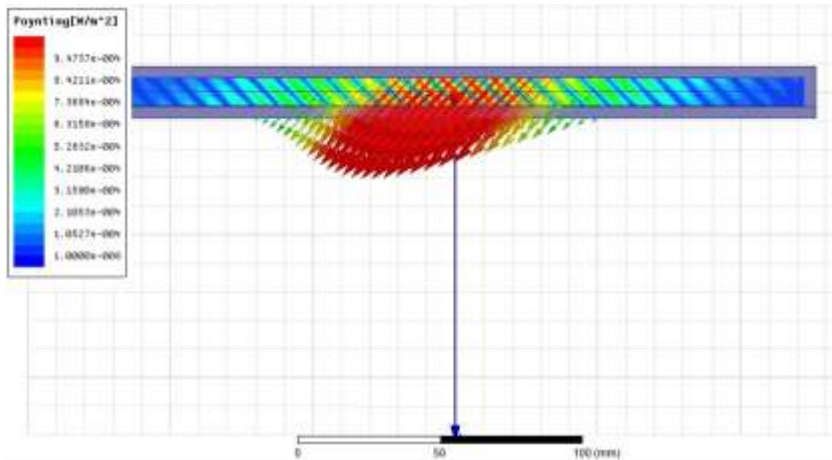

Electric field and power flow through the array plotted

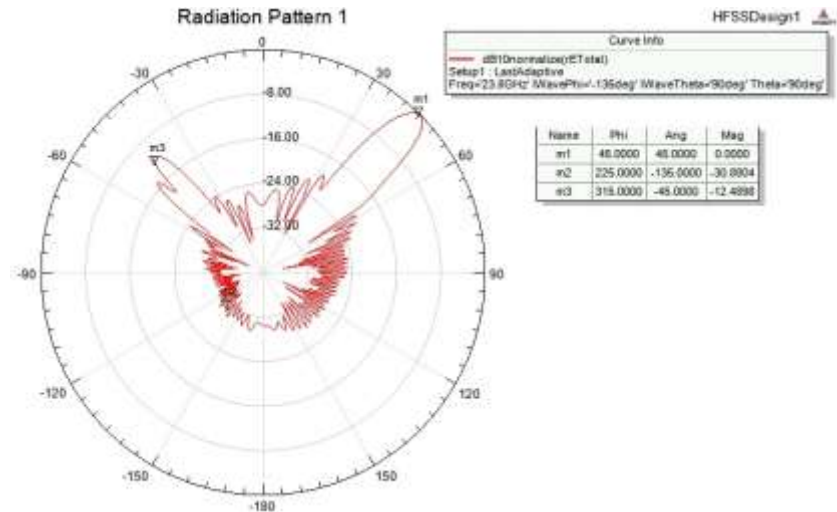

Scattering radiation pattern





# ECIT | Finite FSS Modelling Results (2-2)

- Increased edge illumination, 80 mm radius
- Radiation pattern shows increased levels off the main propagation path
- Power reflected back in incident direction rises to -24 dB
- Main beam side lobes rise from -20 to -10.3 dB

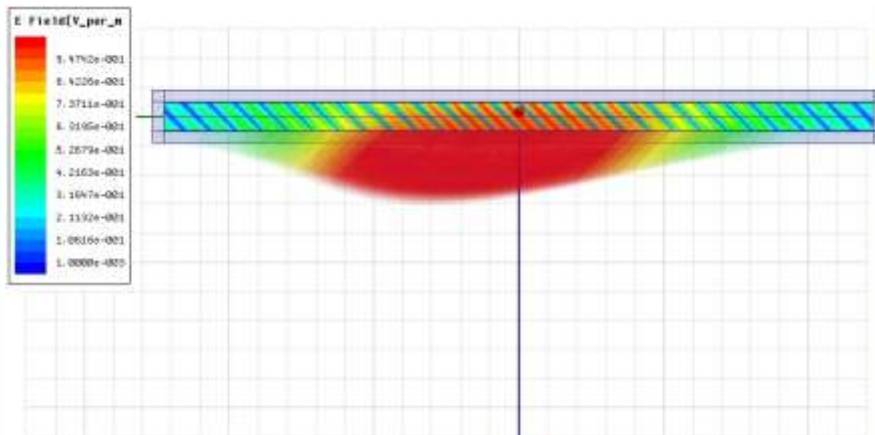

Electric field and power flow through the array

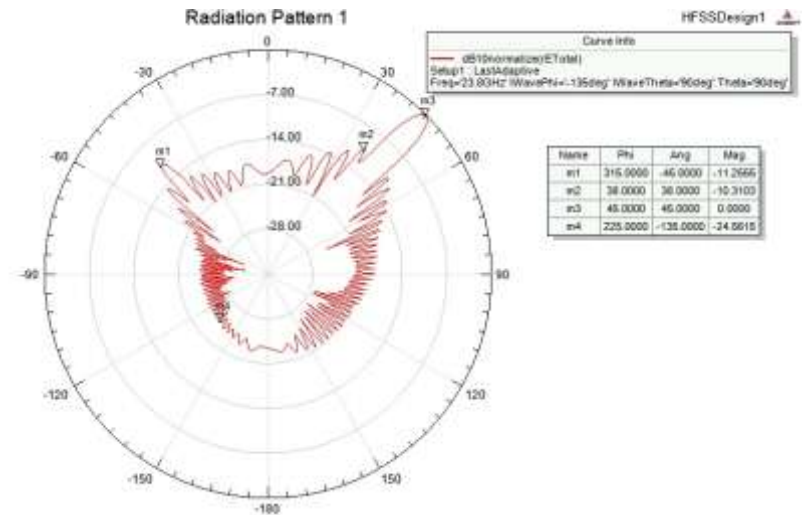

Scattering radiation pattern

- **Procurement Activities:** Procurement of GPU cards, memory and CST software
- **FSS Model Setup:** Two methods were investigated, linear array and complete array modelling
- **Model Convergence:** Development of the finite FSS model, good convergence to the highly accurate infinite array approach, and existing measured data
- **Finite FSS Effects:** Establish edge illumination effects at 23.8 GHz for 45° incidence
  - radiation pattern plots
- **Reporting:** Final report giving final modelled results, model development, comparison with measurements

- Presentations
  - The work reported in the report has/will be disseminated to our partners, and presented at the CEOI workshop
- Publications
  - Planned publication in IET Electronics Letters Journal
- Leverage achieved / Collaborations forged
  - This work particularly important for the MetOp-SG MWS instrument given that the breadboarding phase of the quasi- optical feed network has recently started and will be undertaken by a UK consortium consisting of QUB, RAL Space and QMUL

- Innovative modelling solutions developed to address new and increasingly demanding future mission requirements
  - Results that can be incorporated into QO network design studies
  - FSS models which can determine the edge effects when illuminated by a finite microwave beam
- The work addresses a critical technology need for the MWS instrument which is under development (Phase B) and scheduled for launch in 2020
- Strengthens UK expertise and capabilities in EO instrumentation
- Helps to position us, together with our industrial partners EADS Astrium UK and RAL, to bid for future work

- **Missions/exploitation route**

- The work is aligned with the breadboarding phase of the MWS QO network phase which started in January 2013 by a UK consortium consisting of QUB, RAL Space and QMUL, as described in RFQ 3-13642/12/NL/BJKO
- MicroWave Sounder (MWS), MetOp-SG as described in MOS-SOW-ASU-001

- **Future steps / Technology development required**

- Further development of the complete array modelling by increasing the hardware nodes
- Look at alternative solvers such as FEKO to determine if more efficient complete solutions can be obtained

- **Issues to be resolved**

- Comparing the predicted radiation patterns with measured results, this will take place during the breadboarding phase of the MWS QO network